

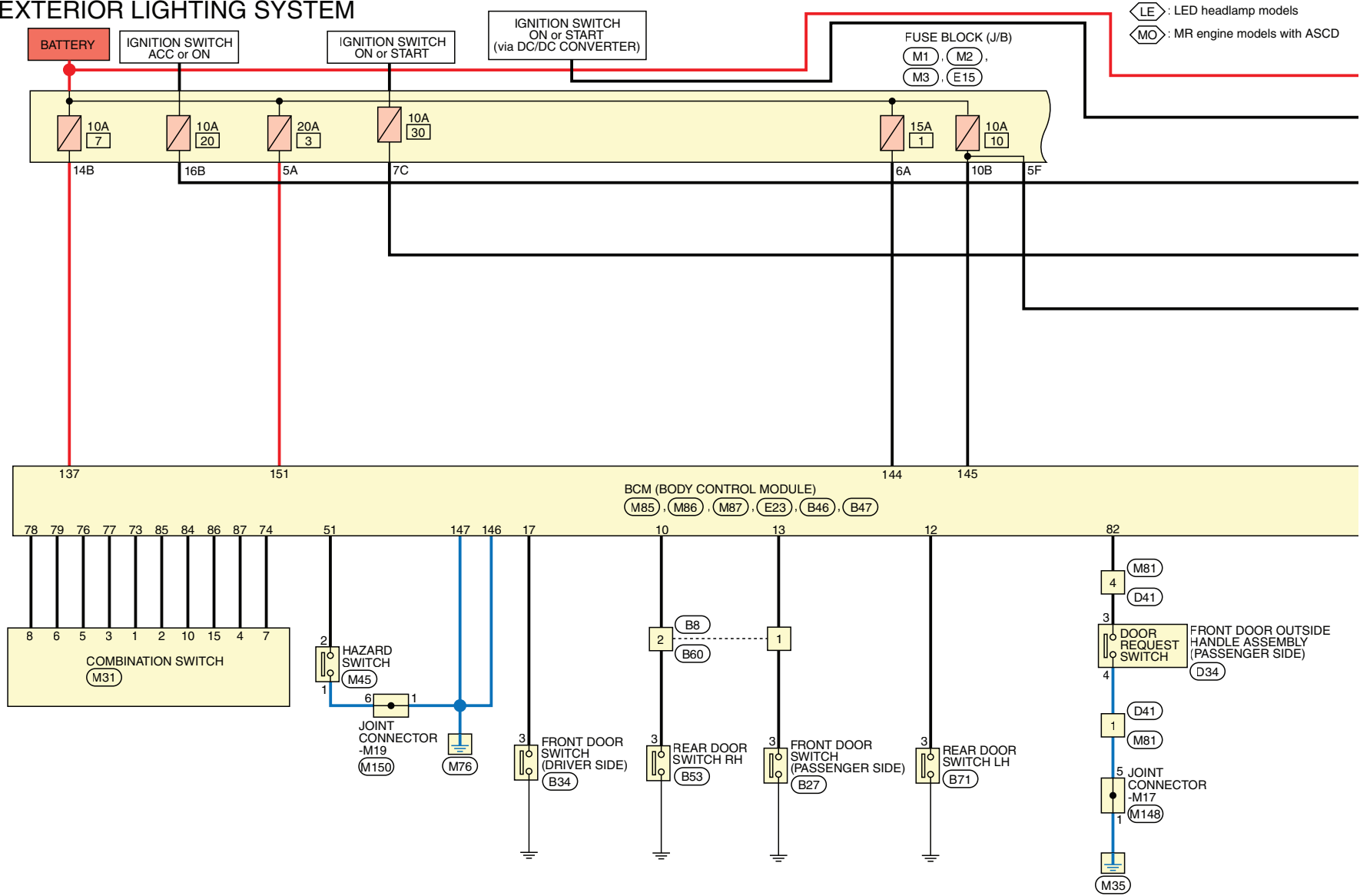







# EXTERIOR LIGHTING SYSTEM



\*1 5:  \*4 116:   
 2:  140:   
 150: 

 : MR engine models  
 : QR engine models  
 : MR20DD engine type 2 models

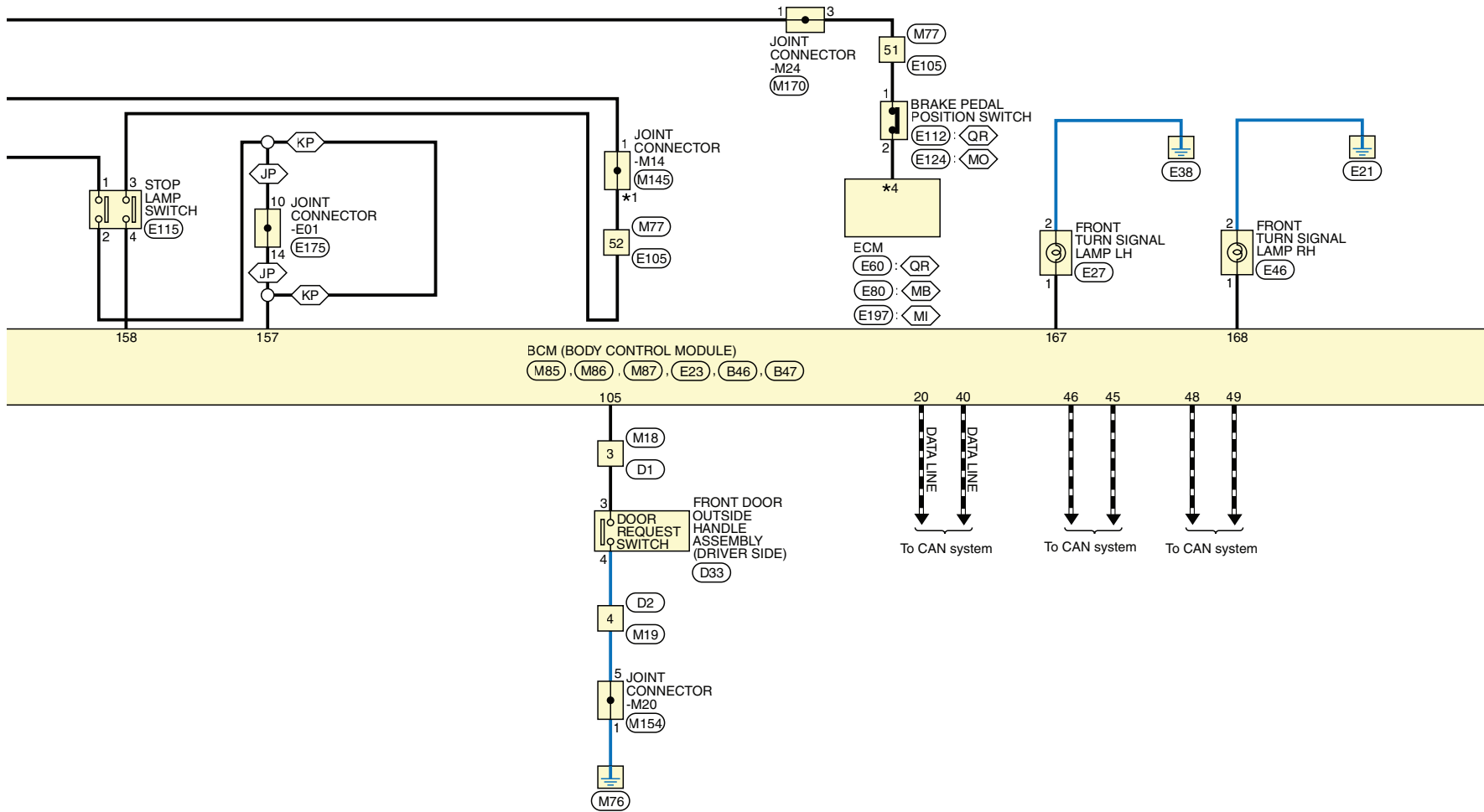

MB : MR20DD engine type 1 models

WC : Without sonar system OFF switch

AL : With optical sensor

CS : With sonar system OFF switch

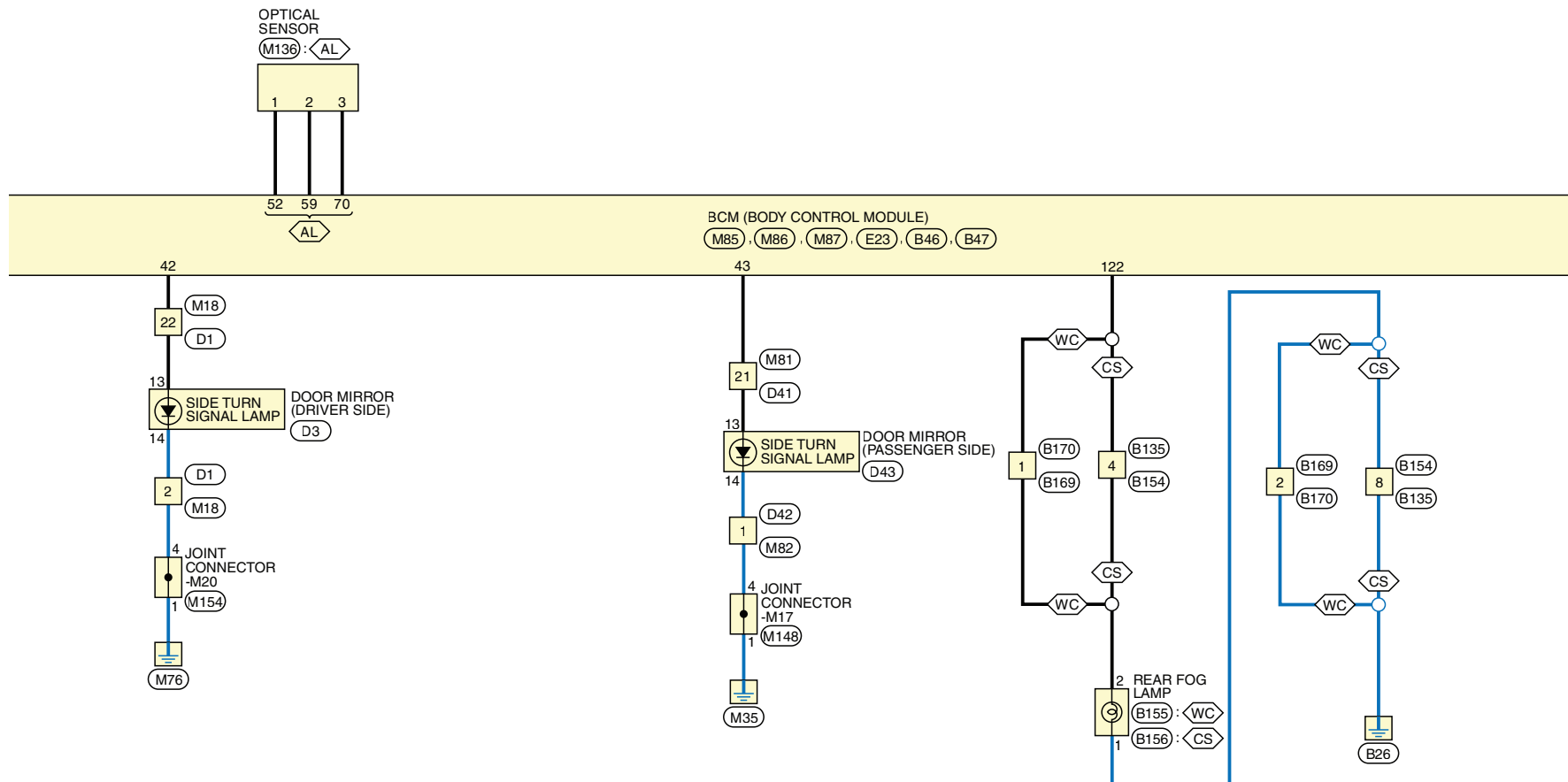

◊JP◊ : Before July 22, 2018 production    ◊AB◊ : With automatic back door system  
 ◊KP◊ : After July 23, 2018 production    ◊OB◊ : Without automatic back door system

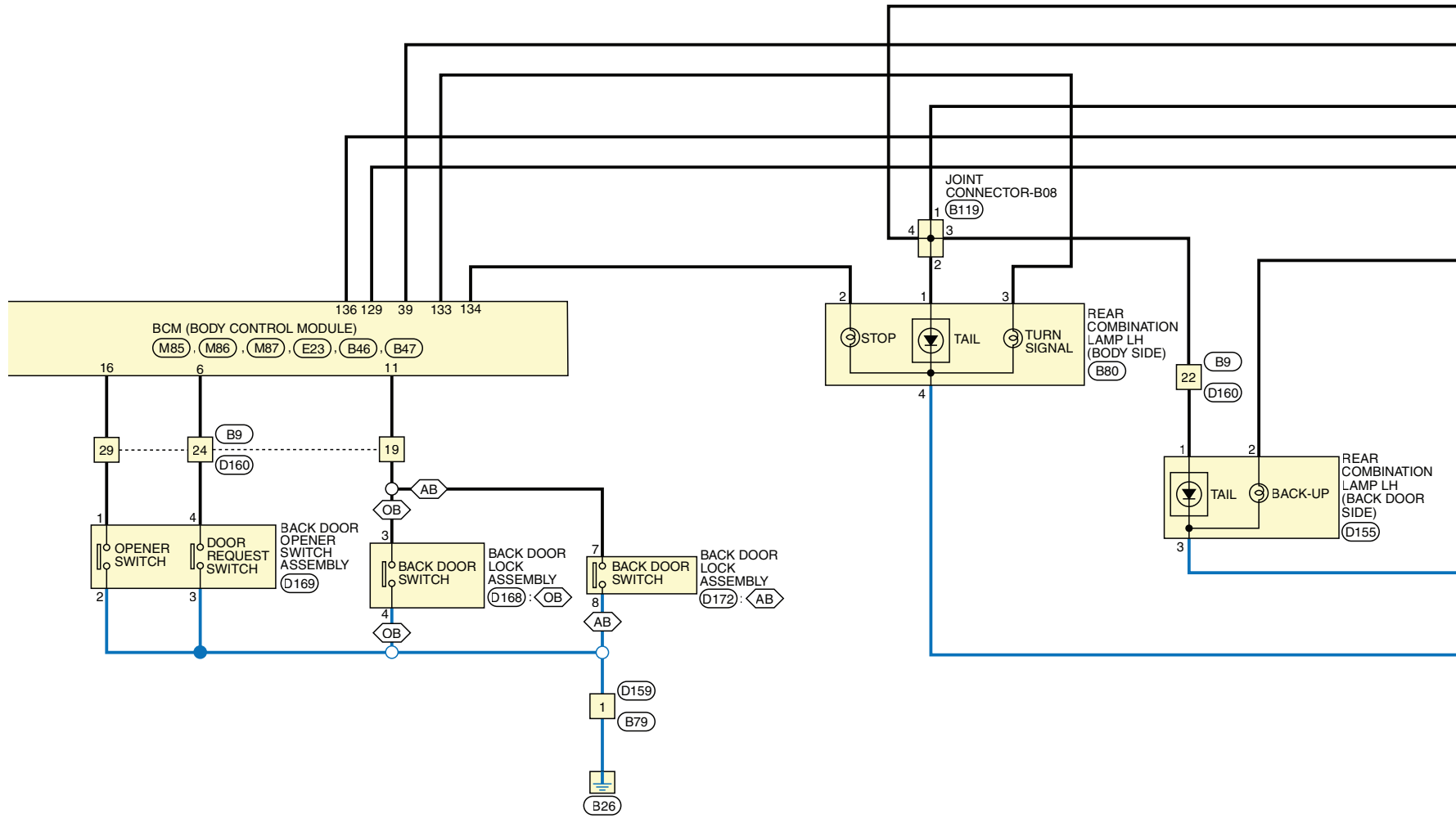

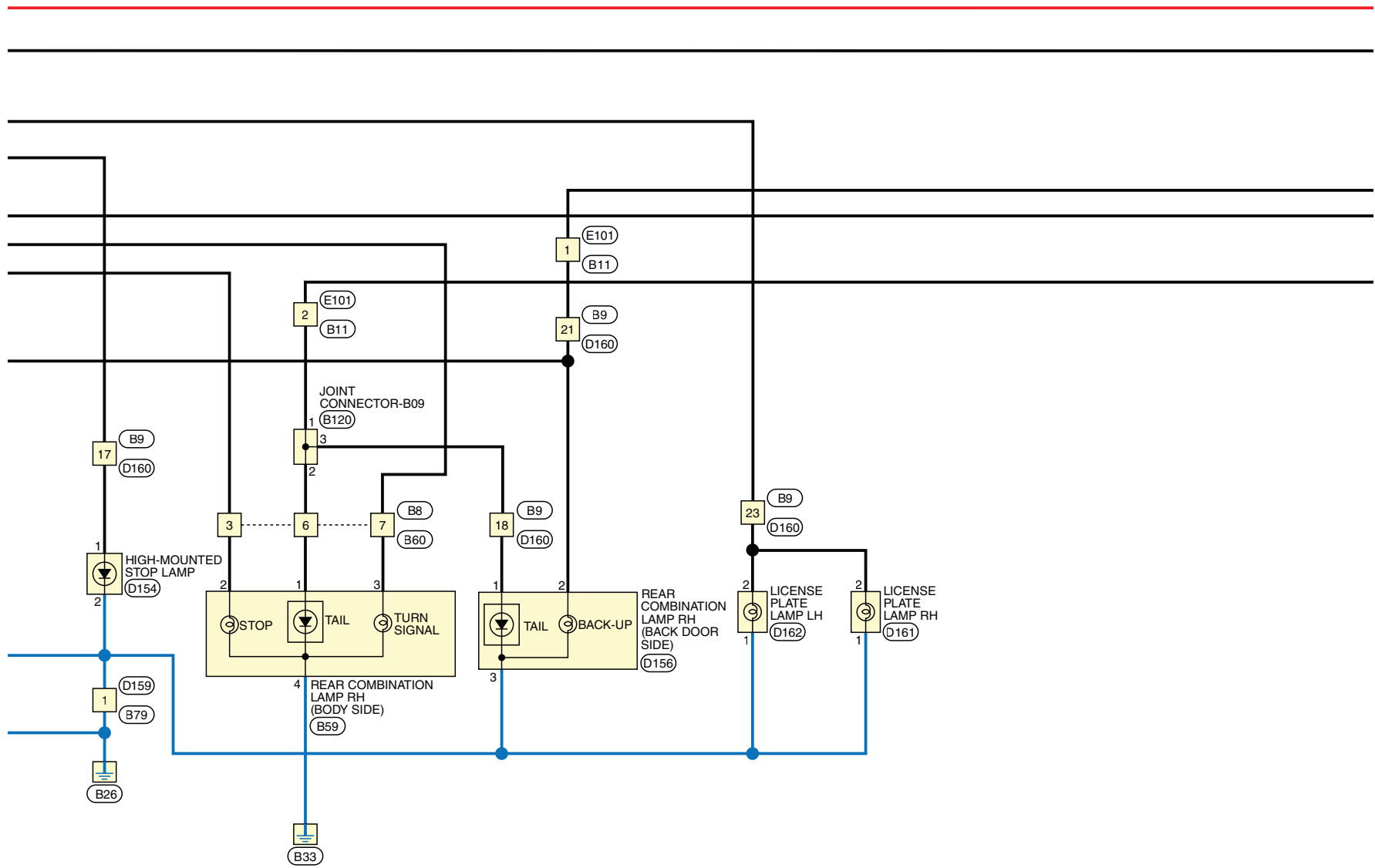

HA : Halogen headlamp models

HM : With headlamp aiming control system (MANUAL)

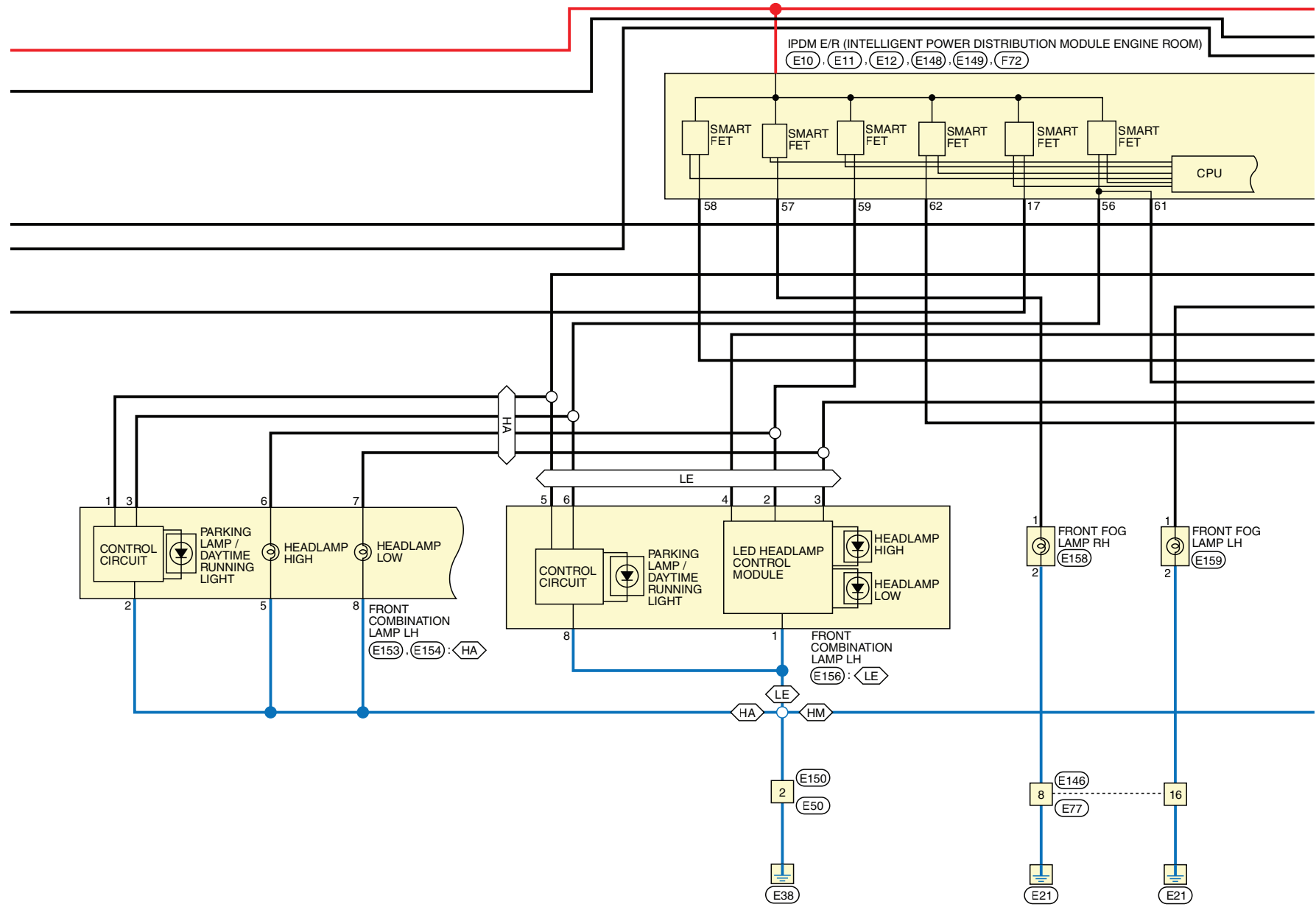

<XS> : Without Stop / Start system    <AH> : With headlamp aiming control system (AUTO)

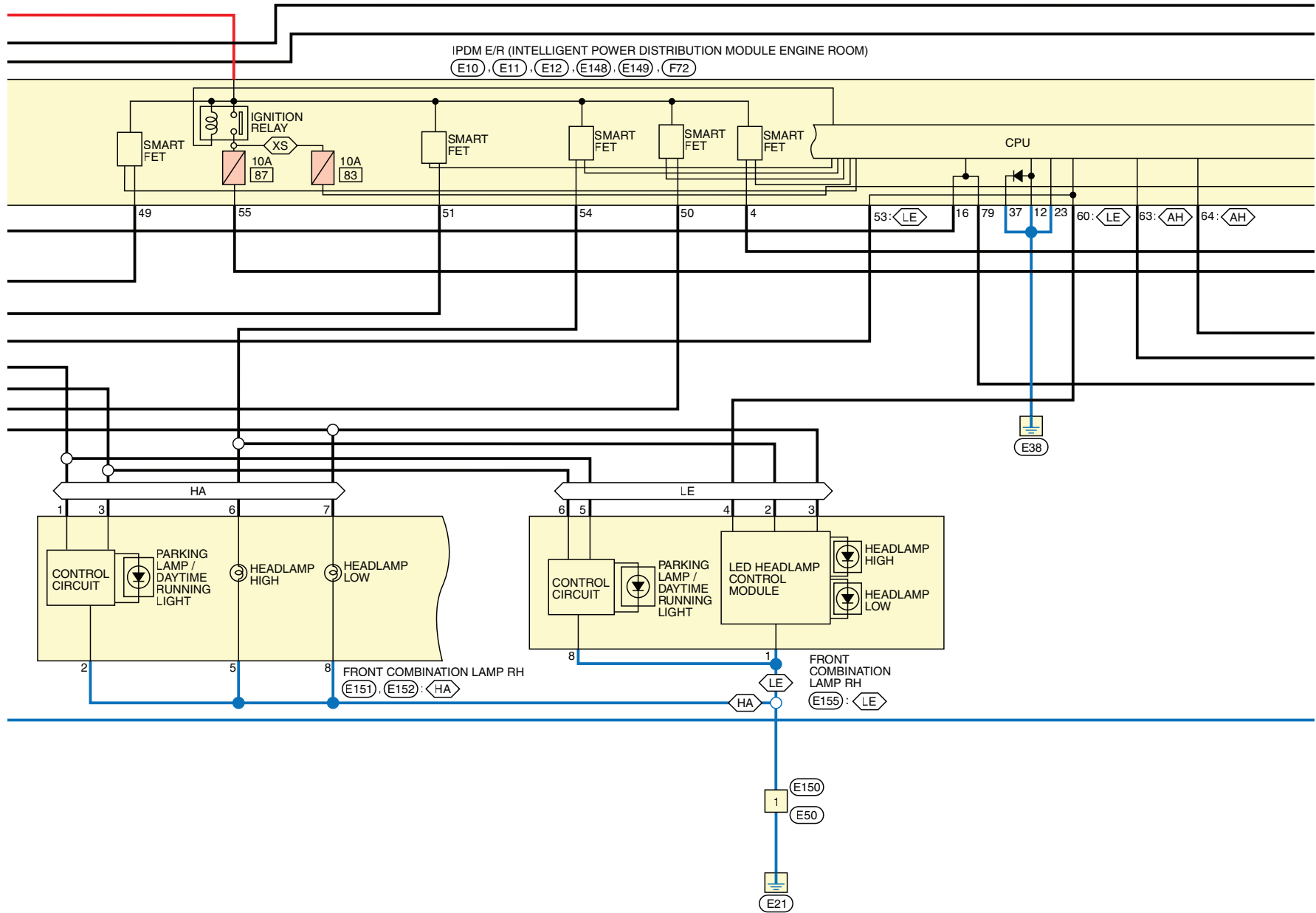

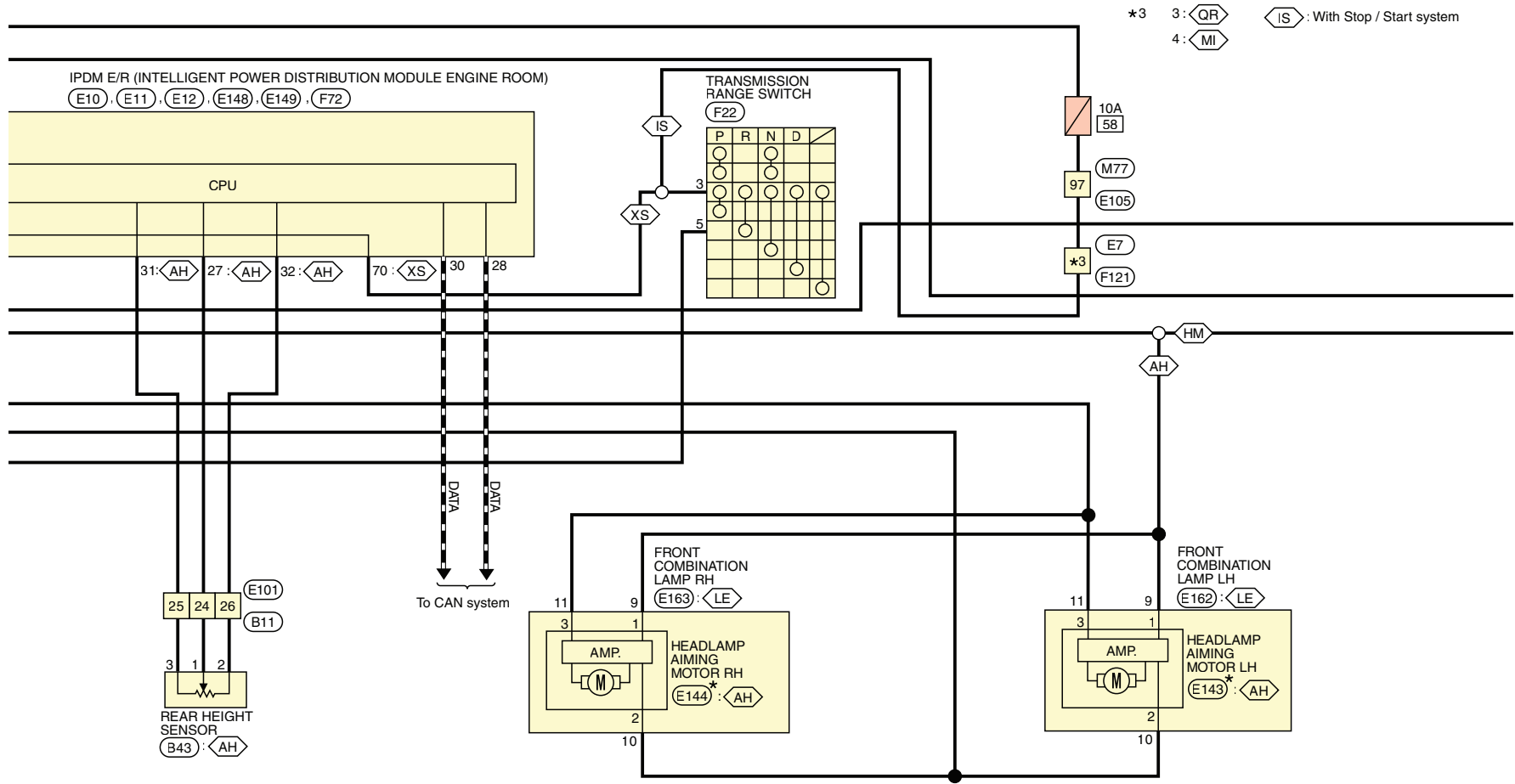

\*2 31 : JP  
 59 : KP

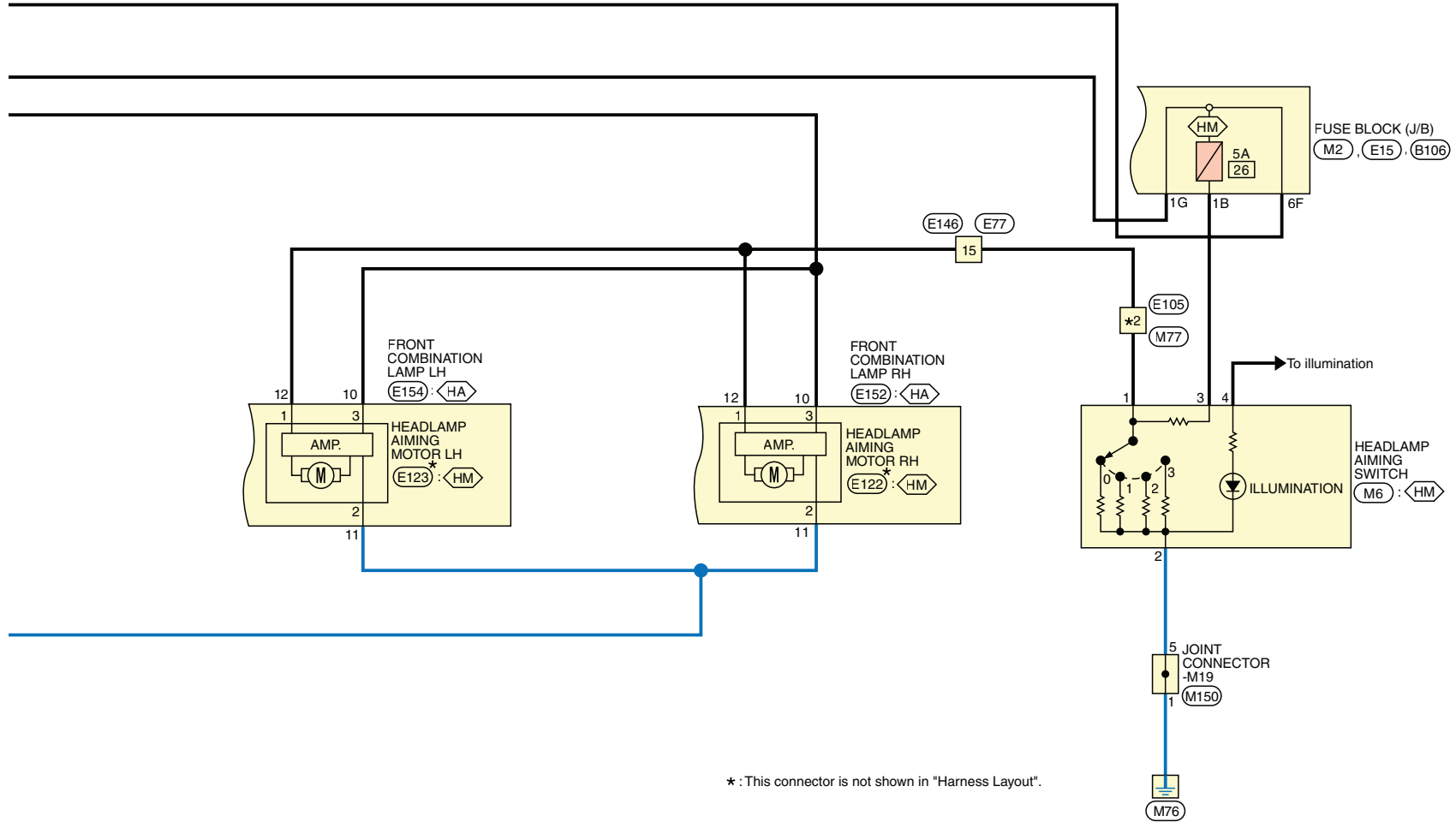

\* : This connector is not shown in "Harness Layout".

## EXTERIOR LIGHTING SYSTEM

Connector No.	B8
Connector Name	WIRE TO WIRE
Connector Type	NS16MW-CS
Connector Color	White

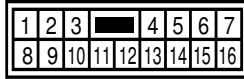

Terminal No.	Color Of Wire	Signal Name [Specification]
1	SB	TO BODY HARNESS
2	W	TO BODY HARNESS
3	LA/W	TO BODY HARNESS
6	LA/BR	TO BODY HARNESS
7	P	TO BODY HARNESS
8	L	TO BODY HARNESS
9	Y	TO BODY HARNESS
11	LA/G	TO BODY HARNESS
12	LA/P	TO BODY HARNESS
13	L	TO BODY HARNESS
14	Y	TO BODY HARNESS
15	G	TO BODY HARNESS
16	V	TO BODY HARNESS

Connector No.	B9
Connector Name	WIRE TO WIRE
Connector Type	TH32MW-NH
Connector Color	White

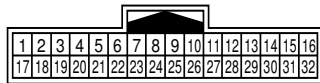

Terminal No.	Color Of Wire	Signal Name [Specification]
5	R	TO BODY HARNESS
6	B	TO BODY HARNESS
7	W	TO BODY HARNESS
8	SHIELD	TO BODY HARNESS

13	W	TO BODY HARNESS
14	V	TO BODY HARNESS
15	BR	TO BODY HARNESS
16	SB	TO BODY HARNESS
17	LA/W	TO BODY HARNESS
18	LA/BR	TO BODY HARNESS
19	LG	TO BODY HARNESS
21	G	TO BODY HARNESS
22	LA/R	TO BODY HARNESS
23	LA/R	TO BODY HARNESS
24	R	TO BODY HARNESS
29	Y	TO BODY HARNESS
30	G	TO BODY HARNESS
31	GR	TO BODY HARNESS
32	LG	TO BODY HARNESS

Connector No.	B11
Connector Name	WIRE TO WIRE
Connector Type	TH80MDGY-CS16-TM4
Connector Color	Dark Gray

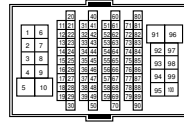

Terminal No.	Color Of Wire	Signal Name [Specification]
1	G	TO ENGINE ROOM HARNESS
2	LA/BR	TO ENGINE ROOM HARNESS
4	LG	TO ENGINE ROOM HARNESS
6	W	TO ENGINE ROOM HARNESS
8	BR	TO ENGINE ROOM HARNESS
11	SB	TO ENGINE ROOM HARNESS
12	V	TO ENGINE ROOM HARNESS
13	P	TO ENGINE ROOM HARNESS
14	W	TO ENGINE ROOM HARNESS
15	G	TO ENGINE ROOM HARNESS
16	LG	TO ENGINE ROOM HARNESS
17	Y	TO ENGINE ROOM HARNESS
20	R	TO ENGINE ROOM HARNESS
21	BR	TO ENGINE ROOM HARNESS
22	Y	TO ENGINE ROOM HARNESS
23	BG	TO ENGINE ROOM HARNESS
24	SB	TO ENGINE ROOM HARNESS

25	G	TO ENGINE ROOM HARNESS
26	B	TO ENGINE ROOM HARNESS
27	L	TO ENGINE ROOM HARNESS
100	SB	TO ENGINE ROOM HARNESS

Connector No.	B27
Connector Name	FRONT DOOR SWITCH (PASSENGER SIDE)
Connector Type	TH04FW-NH
Connector Color	White

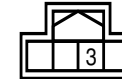

Terminal No.	Color Of Wire	Signal Name [Specification]
3	GR	PASSENGER DOOR SW

Connector No.	B34
Connector Name	FRONT DOOR SWITCH (DRIVER SIDE)
Connector Type	TH04FW-NH
Connector Color	White

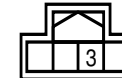

Terminal No.	Color Of Wire	Signal Name [Specification]
3	SB	DRIVER DOOR SW

Connector No.	B43
Connector Name	REAR HEIGHT SENSOR
Connector Type	RH03FB
Connector Color	Black



Terminal No.	Color Of Wire	Signal Name [Specification]
1	SB	REAR HEIGHT SENSOR SIGNAL
2	B	HEIGHT SENSOR GROUND
3	G	HEIGHT SENSOR POWER SUPPLY

Connector No.	B46
Connector Name	BCM (BODY CONTROL MODULE)
Connector Type	NS16FGY-CS
Connector Color	Gray

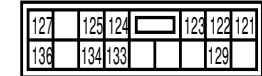

Terminal No.	Color Of Wire	Signal Name [Specification]
121	LA/V	BACK DOOR OPENER CONT
122	Y	REAR FOG LAMP OUTPUT
123	LA/R	REAR WIPER OUTPUT
124	W	REAR DOOR UNLOCK OUTPUT
125	L	REAR DOOR LOCK OUTPUT
127	R	LUGGAGE ROOM LAMP CONT
129	LA/W	STOP LAMP RH OUT
133	GR	TURN SIG LH (REAR)
134	LA/Y	STOP LAMP LH OUT
136	P	TURN SIG RH (REAR)

## EXTERIOR LIGHTING SYSTEM

Connector No.	B47
Connector Name	BCM (BODY CONTROL MODULE)
Connector Type	TH40FG-NH
Connector Color	Green

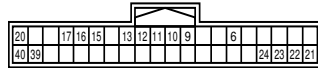

Terminal No.	Color Of Wire	Signal Name [Specification]
6	R	BACK DOOR OPENER REQUEST SW
9	G	HANDS FREE SENSOR
10	W	REAR RH DOOR SW
11	LG	BACK DOOR SW
12	R	REAR LH DOOR SW
13	SB	PASSENGER DOOR SW
15	LA/G	REAR WIPER AUTO STOP
16	Y	BACK DOOR OPENER SW
17	SB	DRIVER DOOR SW
20	L	CAN-H
21	V	BUMPER ANTENNA(-)
22	Y	REAR ANTENNA(-)
23	L	REAR ANTENNA(+)
24	LG	BUMPER ANTENNA(+)
39	LA/W	HIGH-MOUNTED STOP LAMP
40	P	CAN-L

Connector No.	B53
Connector Name	REAR DOOR SWITCH RH
Connector Type	TH04FW-NH
Connector Color	White



Terminal No.	Color Of Wire	Signal Name [Specification]
3	W	REAR RH DOOR SW

Connector No.	B59
Connector Name	REAR COMBINATION LAMP RH (BODY SIDE)
Connector Type	NS04MW-CS
Connector Color	White

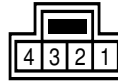

Terminal No.	Color Of Wire	Signal Name [Specification]
1	LA/BR	-
2	LA/Y	-
3	LA/V	-
4	B	-

Connector No.	B60
Connector Name	WIRE TO WIRE
Connector Type	NS16FW-CS
Connector Color	White

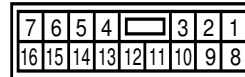

Terminal No.	Color Of Wire	Signal Name [Specification]
1	GR	TO BODY HARNESS
2	W	TO BODY HARNESS
3	LA/Y	TO BODY HARNESS
6	LA/BR	TO BODY HARNESS
7	LA/V	TO BODY HARNESS
8	L	TO BODY HARNESS
9	Y	TO BODY HARNESS
11	R	TO BODY HARNESS
12	L	TO BODY HARNESS

13	L	TO BODY HARNESS
14	Y	TO BODY HARNESS
15	LA/GR	TO BODY HARNESS
16	LA/LG	TO BODY HARNESS

Connector No.	B71
Connector Name	REAR DOOR SWITCH LH
Connector Type	TH04FW-NH
Connector Color	White

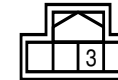

Terminal No.	Color Of Wire	Signal Name [Specification]
3	R	REAR LH DOOR SW

Connector No.	B79
Connector Name	WIRE TO WIRE
Connector Type	M02MW-LC
Connector Color	White



Terminal No.	Color Of Wire	Signal Name [Specification]
1	B	TO BODY HARNESS

Connector No.	B80
Connector Name	REAR COMBINATION LAMP LH (BODY SIDE)
Connector Type	NS04MW-CS
Connector Color	White

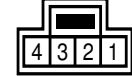

Terminal No.	Color Of Wire	Signal Name [Specification]
1	LA/R	-
2	LA/Y	-
3	GR	-
4	B	-

Connector No.	B106
Connector Name	FUSE BLOCK (J/B)
Connector Type	NS06FW-CS
Connector Color	White

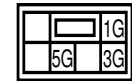

Terminal No.	Color Of Wire	Signal Name [Specification]
1G	LA/R	-
3G	G	-
5G	G	-

## EXTERIOR LIGHTING SYSTEM

Connector No.	B119
Connector Name	JOINT CONNECTOR-B08
Connector Type	SAC04JW
Connector Color	-

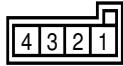

Connector No.	B135
Connector Name	WIRE TO WIRE
Connector Type	RH08MB
Connector Color	Black



Connector No.	B155
Connector Name	REAR FOG LAMP
Connector Type	RS02FGY
Connector Color	Gray



Connector No.	B169
Connector Name	WIRE TO WIRE
Connector Type	RH02FB
Connector Color	Black



Terminal No.	Color Of Wire	Signal Name [Specification]
1	LA/R	-
2	LA/R	-
3	LA/R	-
4	LA/R	-

Terminal No.	Color Of Wire	Signal Name [Specification]
4	Y	TO BODY HARNESS
8	B	TO BODY HARNESS

Terminal No.	Color Of Wire	Signal Name [Specification]
1	B	-
2	Y	-

Terminal No.	Color Of Wire	Signal Name [Specification]
1	Y	TO BODY HARNESS
2	B	TO BODY HARNESS

Connector No.	B120
Connector Name	JOINT CONNECTOR-B09
Connector Type	SAC04JW
Connector Color	-

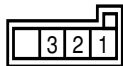

Connector No.	B154
Connector Name	WIRE TO WIRE
Connector Type	RH08FB
Connector Color	Black



Connector No.	B156
Connector Name	REAR FOG LAMP
Connector Type	RS02FGY
Connector Color	Gray



Connector No.	B170
Connector Name	WIRE TO WIRE
Connector Type	RH02MB
Connector Color	Black



Terminal No.	Color Of Wire	Signal Name [Specification]
1	LA/BR	-
2	LA/BR	-
3	LA/BR	-

Terminal No.	Color Of Wire	Signal Name [Specification]
4	Y	TO BODY HARNESS
8	B	TO BODY HARNESS

Terminal No.	Color Of Wire	Signal Name [Specification]
1	B	-
2	Y	-

Terminal No.	Color Of Wire	Signal Name [Specification]
1	Y	TO BODY HARNESS
2	B	TO BODY HARNESS

## EXTERIOR LIGHTING SYSTEM

Connector No.	D1
Connector Name	WIRE TO WIRE
Connector Type	TH24FW-NH
Connector Color	White

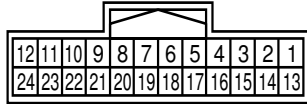

Connector No.	D2
Connector Name	WIRE TO WIRE
Connector Type	NS16FW-CS
Connector Color	White

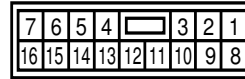

Connector No.	D3
Connector Name	DOOR MIRROR (DRIVER SIDE)
Connector Type	TH16MW-NH
Connector Color	White

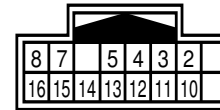

Connector No.	D33
Connector Name	FRONT DOOR OUTSIDE HANDLE ASSEMBLY (DRIVER SIDE)
Connector Type	RH04FB
Connector Color	Black



Terminal No.	Color Of Wire	Signal Name [Specification]
1	B	TO MAIN HARNESS [Color of wire varies depending on production]
1	LA/B	TO MAIN HARNESS [Color of wire varies depending on production]
2	B	TO MAIN HARNESS [Color of wire varies depending on production]
2	LA/B	TO MAIN HARNESS [Color of wire varies depending on production]
3	W	TO MAIN HARNESS
4	V	TO MAIN HARNESS
5	SB	TO MAIN HARNESS
6	LG	TO MAIN HARNESS
7	GR	TO MAIN HARNESS
8	G	TO MAIN HARNESS
9	Y	TO MAIN HARNESS
10	B	TO MAIN HARNESS
11	R	TO MAIN HARNESS
13	LA/W	TO MAIN HARNESS [Color of wire varies depending on production]
13	W	TO MAIN HARNESS [Color of wire varies depending on production]
14	LA/Y	TO MAIN HARNESS [Color of wire varies depending on production]
14	Y	TO MAIN HARNESS [Color of wire varies depending on production]
15	LA/LG	TO MAIN HARNESS [Color of wire varies depending on production]
15	LG	TO MAIN HARNESS [Color of wire varies depending on production]
16	LA/V	TO MAIN HARNESS [Color of wire varies depending on production]
16	V	TO MAIN HARNESS [Color of wire varies depending on production]
17	L	TO MAIN HARNESS [Color of wire varies depending on production]
17	LA/L	TO MAIN HARNESS [Color of wire varies depending on production]
18	BG	TO MAIN HARNESS [Color of wire varies depending on production]
18	LA/BG	TO MAIN HARNESS [Color of wire varies depending on production]
19	LA/R	TO MAIN HARNESS [Color of wire varies depending on production]
19	R	TO MAIN HARNESS [Color of wire varies depending on production]
22	G	TO MAIN HARNESS [Color of wire varies depending on production]
22	LA/G	TO MAIN HARNESS [Color of wire varies depending on production]
23	L	TO MAIN HARNESS
24	BG	TO MAIN HARNESS

Terminal No.	Color Of Wire	Signal Name [Specification]
1	LA/V	TO MAIN HARNESS [Color of wire varies depending on production]
1	V	TO MAIN HARNESS [Color of wire varies depending on production]
2	R	TO MAIN HARNESS
3	G	TO MAIN HARNESS [Color of wire varies depending on production]
3	LA/G	TO MAIN HARNESS [Color of wire varies depending on production]
4	B	TO MAIN HARNESS
6	L	TO MAIN HARNESS [With 8-speakers]
6	LA/L	TO MAIN HARNESS [With 4-speakers or 6-speakers]
7	BR	TO MAIN HARNESS [With 8-speakers]
7	LA/BR	TO MAIN HARNESS [With 4-speakers or 6-speakers]
8	SB	TO MAIN HARNESS
9	GR	TO MAIN HARNESS [Color of wire varies depending on production]
9	LA/GR	TO MAIN HARNESS [Color of wire varies depending on production]
10	LA/SB	TO MAIN HARNESS [Color of wire varies depending on production]
10	SB	TO MAIN HARNESS [Color of wire varies depending on production]
11	P	TO MAIN HARNESS
12	LG	TO MAIN HARNESS
13	LA/Y	TO MAIN HARNESS [Color of wire varies depending on production]
13	Y	TO MAIN HARNESS [Color of wire varies depending on production]
14	LA/W	TO MAIN HARNESS [Color of wire varies depending on production]
14	W	TO MAIN HARNESS [Color of wire varies depending on production]
15	LA/R	TO MAIN HARNESS [Color of wire varies depending on production]
15	R	TO MAIN HARNESS [Color of wire varies depending on production]
16	B	TO MAIN HARNESS

Terminal No.	Color Of Wire	Signal Name [Specification]
2	LG	-
3	LA/P	- [Color of wire varies depending on production]
3	P	- [Color of wire varies depending on production]
4	BR	- [Color of wire varies depending on production]
4	LA/BR	- [Color of wire varies depending on production]
5	LA/W	- [Color of wire varies depending on production]
5	W	- [Color of wire varies depending on production]
7	GR	-
8	G	-
10	B	-
11	LA/SB	- [Color of wire varies depending on production]
11	SB	- [Color of wire varies depending on production]
12	GR	- [Color of wire varies depending on production]
12	LA/GR	- [Color of wire varies depending on production]
13	G	- [Color of wire varies depending on production]
13	LA/G	- [Color of wire varies depending on production]
14	B	- [Color of wire varies depending on production]
14	LA/B	- [Color of wire varies depending on production]
15	B	-
16	Y	-

Terminal No.	Color Of Wire	Signal Name [Specification]
1	V	DRIVER DOOR ANT +
2	SB	RRIVER DOOR ANT +
3	W	DR DOOR REQ SW
4	B	FRONT DOOR OUTSIDE HANDLE ASSEMBLY (DRIVER SIDE) GROUND

Connector No.	D34
Connector Name	FRONT DOOR OUTSIDE HANDLE ASSEMBLY (PASSENGER SIDE)
Connector Type	RH04FB
Connector Color	Black



Terminal No.	Color Of Wire	Signal Name [Specification]
1	R	PASSENGER DOOR ANT +
2	SB	PASSENGER DOOR ANT -
3	P	PASS DOOR REQ SW
4	B	FRONT DOOR OUTSIDE HANDLE ASSEMBLY (PASSENGER SIDE) GROUND

## EXTERIOR LIGHTING SYSTEM

Connector No.	D41
Connector Name	WIRE TO WIRE
Connector Type	TH24FW-NH
Connector Color	White

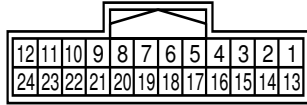

Terminal No.	Color Of Wire	Signal Name [Specification]
1	B	TO MAIN HARNESS
3	B	TO MAIN HARNESS
4	P	TO MAIN HARNESS
5	R	TO MAIN HARNESS
6	SB	TO MAIN HARNESS
7	L	TO MAIN HARNESS
8	V	TO MAIN HARNESS
9	Y	TO MAIN HARNESS
10	B	TO MAIN HARNESS
11	G	TO MAIN HARNESS
13	LA/Y	TO MAIN HARNESS [Color of wire varies depending on production]
13	Y	TO MAIN HARNESS [Color of wire varies depending on production]
14	LA/R	TO MAIN HARNESS [Color of wire varies depending on production]
14	R	TO MAIN HARNESS [Color of wire varies depending on production]
15	LA/V	TO MAIN HARNESS [Color of wire varies depending on production]
15	V	TO MAIN HARNESS [Color of wire varies depending on production]
16	L	TO MAIN HARNESS [Color of wire varies depending on production]
16	LA/L	TO MAIN HARNESS [Color of wire varies depending on production]
17	BG	TO MAIN HARNESS [Color of wire varies depending on production]
17	LA/BG	TO MAIN HARNESS [Color of wire varies depending on production]
18	GR	TO MAIN HARNESS
21	G	TO MAIN HARNESS [Color of wire varies depending on production]
21	LA/G	TO MAIN HARNESS [Color of wire varies depending on production]

Connector No.	D42
Connector Name	WIRE TO WIRE
Connector Type	NS16FW-CS
Connector Color	White

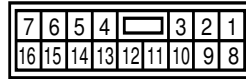

Terminal No.	Color Of Wire	Signal Name [Specification]
1	B	TO MAIN HARNESS [Color of wire varies depending on production]
1	LA/B	TO MAIN HARNESS [Color of wire varies depending on production]
2	B	TO MAIN HARNESS
8	GR	TO MAIN HARNESS [Color of wire varies depending on production]
8	LA/GR	TO MAIN HARNESS [Color of wire varies depending on production]
9	LA/Y	TO MAIN HARNESS [Color of wire varies depending on production]
9	Y	TO MAIN HARNESS [Color of wire varies depending on production]
10	BR	TO MAIN HARNESS [Color of wire varies depending on production]
10	LA/BR	TO MAIN HARNESS [Color of wire varies depending on production]
11	L	TO MAIN HARNESS [Color of wire varies depending on production]
11	LA/L	TO MAIN HARNESS [Color of wire varies depending on production]
12	LA/V	TO MAIN HARNESS [Color of wire varies depending on production]
12	V	TO MAIN HARNESS [Color of wire varies depending on production]
13	LA/R	TO MAIN HARNESS [With 4-speakers or 6-speakers]
13	R	TO MAIN HARNESS [With 8-speakers]
14	G	TO MAIN HARNESS [With 8-speakers]
14	LA/G	TO MAIN HARNESS [With 4-speakers or 6-speakers]

Connector No.	D43
Connector Name	DOOR MIRROR (PASSENGER SIDE)
Connector Type	TH16MW-NH
Connector Color	White

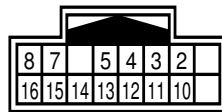

Terminal No.	Color Of Wire	Signal Name [Specification]
2	GR	-
3	L	- [Color of wire varies depending on production]
3	LA/L	- [Color of wire varies depending on production]
4	LA/R	- [Color of wire varies depending on production]
4	R	- [Color of wire varies depending on production]
5	LA/Y	- [Color of wire varies depending on production]
5	Y	- [Color of wire varies depending on production]
7	L	-
8	V	-
10	B	-
11	BG	- [Color of wire varies depending on production]
11	LA/BG	- [Color of wire varies depending on production]
12	LA/V	- [Color of wire varies depending on production]
12	V	- [Color of wire varies depending on production]
13	G	- [Color of wire varies depending on production]
13	LA/G	- [Color of wire varies depending on production]
14	B	- [Color of wire varies depending on production]
14	LA/B	- [Color of wire varies depending on production]
15	B	-
16	Y	-

Connector No.	D154
Connector Name	HIGH-MOUNTED STOP LAMP
Connector Type	TK02MW
Connector Color	White



Terminal No.	Color Of Wire	Signal Name [Specification]
1	Y	-
2	B	-

Connector No.	D155
Connector Name	REAR COMBINATION LAMP LH (BACK DOOR SIDE)
Connector Type	NS03MW-CS
Connector Color	White



Terminal No.	Color Of Wire	Signal Name [Specification]
1	LA/Y	- [Color of wire varies depending on production]
1	Y	- [Color of wire varies depending on production]
2	G	-
3	GR	-

Connector No.	D156
Connector Name	REAR COMBINATION LAMP RH (BACK DOOR SIDE)
Connector Type	NS03MW-CS
Connector Color	White



Terminal No.	Color Of Wire	Signal Name [Specification]
1	LA/R	- [Color of wire varies depending on production]
1	R	- [Color of wire varies depending on production]
2	L	-
3	GR	-

## EXTERIOR LIGHTING SYSTEM

Connector No.	D159
Connector Name	WIRE TO WIRE
Connector Type	M02FW-LC
Connector Color	White



Terminal No.	Color Of Wire	Signal Name [Specification]
1	B	TO BODY HARNESS

Connector No.	D160
Connector Name	WIRE TO WIRE
Connector Type	TH32FW-NH
Connector Color	White

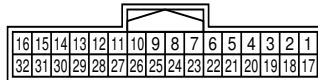

Terminal No.	Color Of Wire	Signal Name [Specification]
5	R	TO BODY HARNESS
6	B	TO BODY HARNESS
7	W	TO BODY HARNESS
8	V	TO BODY HARNESS
13	G	TO BODY HARNESS
14	GR	TO BODY HARNESS [Color of wire varies depending on production]
14	LA/GR	TO BODY HARNESS [Color of wire varies depending on production]
15	LA/W	TO BODY HARNESS [Color of wire varies depending on production]
15	W	TO BODY HARNESS [Color of wire varies depending on production]
16	LA/LG	TO BODY HARNESS [Color of wire varies depending on production]
16	LG	TO BODY HARNESS [Color of wire varies depending on production]
17	Y	TO BODY HARNESS
18	LA/R	TO BODY HARNESS [Color of wire varies depending on production]
18	R	TO BODY HARNESS [Color of wire varies depending on production]
19	W	TO BODY HARNESS
21	G	TO BODY HARNESS
22	LA/Y	TO BODY HARNESS [Color of wire varies depending on production]

22	Y	TO BODY HARNESS [Color of wire varies depending on production]
23	P	TO BODY HARNESS
24	BR	TO BODY HARNESS
29	V	TO BODY HARNESS
30	G	TO BODY HARNESS
31	BG	TO BODY HARNESS
32	LG	TO BODY HARNESS

Connector No.	D161
Connector Name	LICENSE PLATE LAMP RH
Connector Type	TK02FBR
Connector Color	Brown



Terminal No.	Color Of Wire	Signal Name [Specification]
1	B	-
2	R	-

Connector No.	D162
Connector Name	LICENSE PLATE LAMP LH
Connector Type	TK02FBR
Connector Color	Brown



Terminal No.	Color Of Wire	Signal Name [Specification]
1	B	-
2	P	-

Connector No.	D168
Connector Name	BACK DOOR LOCK ASSEMBLY
Connector Type	NS04FW-CS
Connector Color	White

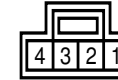

Terminal No.	Color Of Wire	Signal Name [Specification]
1	LA/V	- [Color of wire varies depending on production]
1	V	- [Color of wire varies depending on production]
2	GR	-
3	W	-
4	GR	-

Connector No.	D169
Connector Name	BACK DOOR OPENER SWITCH ASSEMBLY
Connector Type	TH04MW-NH
Connector Color	White



Terminal No.	Color Of Wire	Signal Name [Specification]
1	V	BACK DOOR OPENER SW
2	GR	BACK DOOR OPENER SWITCH ASSEMBLY GROUND
3	GR	BACK DOOR OPENER SWITCH ASSEMBLY GROUND
4	BR	BACK DOOR OPENER REQUEST SW

Connector No.	D172
Connector Name	BACK DOOR LOCK ASSEMBLY
Connector Type	NS08FW-CS
Connector Color	White

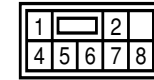

Terminal No.	Color Of Wire	Signal Name [Specification]
1	L	- [Color of wire varies depending on production]
1	LA/L	- [Color of wire varies depending on production]
2	G	- [Color of wire varies depending on production]
2	LA/G	- [Color of wire varies depending on production]
4	GR	- [Color of wire varies depending on production]
4	LA/GR	- [Color of wire varies depending on production]
5	LA/W	- [Color of wire varies depending on production]
5	W	- [Color of wire varies depending on production]
6	LA/LG	- [Color of wire varies depending on production]
6	LG	- [Color of wire varies depending on production]
7	W	-
8	B	-

Connector No.	E7
Connector Name	WIRE TO WIRE
Connector Type	NS16MBR-CS
Connector Color	Brown

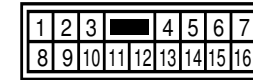

Terminal No.	Color Of Wire	Signal Name [Specification]
1	BR	TO ENGINE CONTROL HARNESS
2	BR	TO ENGINE CONTROL HARNESS
3	R	TO ENGINE CONTROL HARNESS
4	BG	TO ENGINE CONTROL HARNESS [2WD models]
4	R	TO ENGINE CONTROL HARNESS [4WD models]
5	P	TO ENGINE CONTROL HARNESS [2WD models]

## EXTERIOR LIGHTING SYSTEM

5	R	TO ENGINE CONTROL HARNESS [4WD models]
6	BG	TO ENGINE CONTROL HARNESS [Color of wire varies depending on production]
6	BR	TO ENGINE CONTROL HARNESS [Color of wire varies depending on production]
7	G	TO ENGINE CONTROL HARNESS
8	V	TO ENGINE CONTROL HARNESS [2WD models]
8	W	TO ENGINE CONTROL HARNESS [4WD models]
9	BR	TO ENGINE CONTROL HARNESS [2WD models]
9	V	TO ENGINE CONTROL HARNESS [4WD models]
10	BR	TO ENGINE CONTROL HARNESS
11	L	TO ENGINE CONTROL HARNESS [With MR engine]
11	Y	TO ENGINE CONTROL HARNESS [Without MR engine]
12	W	TO ENGINE CONTROL HARNESS
13	BR	TO ENGINE CONTROL HARNESS
14	R	TO ENGINE CONTROL HARNESS [Color of wire varies depending on production]
14	Y	TO ENGINE CONTROL HARNESS [Color of wire varies depending on production]
15	L	TO ENGINE CONTROL HARNESS
16	SB	TO ENGINE CONTROL HARNESS

Connector No.	E10
Connector Name	IPDM E/R (INTELLIGENT POWER DISTRIBUTION MODULE ENGINE ROOM)
Connector Type	NS16FGY-CS
Connector Color	Gray

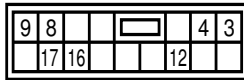

Terminal No.	Color Of Wire	Signal Name [Specification]
3	P	-
4	Y	-
8	BG	-
9	L	-
12	B	-
16	G	-
17	W	-

Connector No.	E11
Connector Name	IPDM E/R (INTELLIGENT POWER DISTRIBUTION MODULE ENGINE ROOM)
Connector Type	renault_243405408R
Connector Color	-



Terminal No.	Color Of Wire	Signal Name [Specification]
19	V	-
20	R	-
22	Y	-
23	B	-
24	W	-

Connector No.	E12
Connector Name	IPDM E/R (INTELLIGENT POWER DISTRIBUTION MODULE ENGINE ROOM)
Connector Type	TH24FGY-NH
Connector Color	Gray

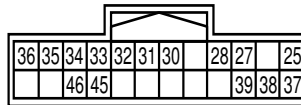

Terminal No.	Color Of Wire	Signal Name [Specification]
25	LG	-
27	SB	-
28	P	-
30	L	-
31	G	-
32	B	-
33	BG	-
34	LG	-
35	V	-
36	Y	-
37	B	-
38	GR	-
39	BR	-

45	L	-
46	P	-

Connector No.	E15
Connector Name	FUSE BLOCK (J/B)
Connector Type	NS10FW-CS
Connector Color	White



Terminal No.	Color Of Wire	Signal Name [Specification]
5F	V	-
6F	Y	-

Connector No.	E23
Connector Name	BCM (BODY CONTROL MODULE)
Connector Type	TH24FB-NH
Connector Color	Black

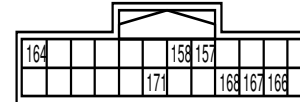

Terminal No.	Color Of Wire	Signal Name [Specification]
157	LG	STOP LAMP SW 2
158	W	STOP LAMP SW 1
164	G	INTELLIGENT KEY WARNING BUZZER
166	P	STEERING LOCK UNIT POWER SUPPLY
167	BR	TURN SIG LH (FRONT)
168	GR	TURN SIG RH (FRONT)
171	G	STARTER RELAY CONT

Connector No.	E27
Connector Name	FRONT TURN SIGNAL LAMP LH
Connector Type	RS02FGY
Connector Color	Gray



Terminal No.	Color Of Wire	Signal Name [Specification]
1	BR	-
2	B	-

Connector No.	E46
Connector Name	FRONT TURN SIGNAL LAMP RH
Connector Type	RS02FGY
Connector Color	Gray



Terminal No.	Color Of Wire	Signal Name [Specification]
1	GR	-
2	BR	-

## EXTERIOR LIGHTING SYSTEM

Connector No.	E50
Connector Name	WIRE TO WIRE
Connector Type	M02MW-GY-LC
Connector Color	White



Terminal No.	Color Of Wire	Signal Name [Specification]
1	GR	TO ENGINE ROOM HARNESS
2	B	TO ENGINE ROOM HARNESS

Connector No.	E60
Connector Name	ECM
Connector Type	RH24FB-RZ8-L-LH
Connector Color	Black

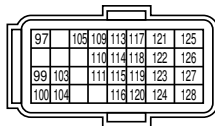

Terminal No.	Color Of Wire	Signal Name [Specification]
97	R	EVAP CANISTER VENT CONTROL VALVE
99	P	CAN COMMUNICATION LINE (CAN-L)
100	L	CAN COMMUNICATION LINE (CAN-H)
103	Y	REFRIGERANT PRESSURE SENSOR
104	R	SENSOR POWER SUPPLY
105	Y	ENGINE RESTART RELAY CONTROL SIGNAL
109	LG	IGNITION SWITCH
110	G	ASCD STEERING SWITCH
111	BR	SENSOR GROUND
113	G	SENSOR POWER SUPPLY
114	L	EVAP CONTROL SYSTEM PRESSURE SENSOR
115	V	STOP LAMP SWITCH
116	GR	BRAKE PEDAL POSITION SWITCH
117	W	PNP SIGNAL
118	SB	SENSOR POWER SUPPLY
119	Y	ACCELERATOR PEDAL POSITION SENSOR 2

120	LG	SENSOR GROUND
121	BR	POWER SUPPLY FOR ECM
122	V	SENSOR POWER SUPPLY
123	BR	ECM GROUND
124	W	SENSOR GROUND
125	BG	FUEL TANK TEMPERATURE SENSOR
126	GR	ACCELERATOR PEDAL POSITION SENSOR 1
127	R	SENSOR GROUND
128	BR	ECM GROUND

Connector No.	E77
Connector Name	WIRE TO WIRE
Connector Type	TH16MW-NH
Connector Color	White

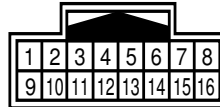

Terminal No.	Color Of Wire	Signal Name [Specification]
1	V	TO ENGINE ROOM HARNESS
2	L	TO ENGINE ROOM HARNESS
3	SB	TO ENGINE ROOM HARNESS
4	P	TO ENGINE ROOM HARNESS
5	G	TO ENGINE ROOM HARNESS
8	GR	TO ENGINE ROOM HARNESS
9	SHIELD	TO ENGINE ROOM HARNESS
10	LG	TO ENGINE ROOM HARNESS
11	V	TO ENGINE ROOM HARNESS
12	W	TO ENGINE ROOM HARNESS
13	LG	TO ENGINE ROOM HARNESS
15	Y	TO ENGINE ROOM HARNESS
16	GR	TO ENGINE ROOM HARNESS

Connector No.	E80
Connector Name	ECM
Connector Type	RH24FB-RZ8-L-LH
Connector Color	Black

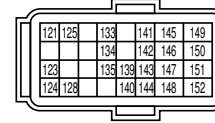

Terminal No.	Color Of Wire	Signal Name [Specification]
121	L	EVAP CONTROL SYSTEM PRESSURE SENSOR
123	P	CAN-L
124	L	CAN-H
125	G	SENSOR POWER SUPPLY
128	BG	FUEL TANK TEMPERATURE SENSOR
133	LG	IGNITION SWITCH
134	G	ASCD STEERING SWITCH
135	BR	SENSOR GROUND
139	V	STOP LAMP SWITCH
140	GR	BRAKE PEDAL POSITION SWITCH
141	R	EVAP CANISTER VENT CONTROL VALVE
142	SB	SENSOR POWER SUPPLY
143	Y	ACCELERATOR PEDAL POSITION SENSOR 2
144	LG	SENSOR GROUND
145	BR	POWER SUPPLY FOR ECM
146	V	SENSOR POWER SUPPLY
147	B	ECM GROUND
148	B	SENSOR GROUND
149	B	ECM GROUND
150	GR	ACCELERATOR PEDAL POSITION SENSOR 1
151	R	SENSOR GROUND
152	B	ECM GROUND

Connector No.	E101
Connector Name	WIRE TO WIRE
Connector Type	TH80FDGY-CS16-TM4
Connector Color	Dark Gray

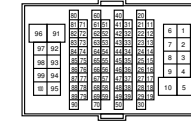

Terminal No.	Color Of Wire	Signal Name [Specification]
1	G	TO BODY HARNESS
2	W	TO BODY HARNESS
4	LG	TO BODY HARNESS
6	BR	TO BODY HARNESS
8	BR	TO BODY HARNESS
11	SB	TO BODY HARNESS
12	V	TO BODY HARNESS
13	P	TO BODY HARNESS
14	W	TO BODY HARNESS
15	G	TO BODY HARNESS
16	LG	TO BODY HARNESS
17	Y	TO BODY HARNESS
20	G	TO BODY HARNESS
21	BR	TO BODY HARNESS
22	LG	TO BODY HARNESS
23	Y	TO BODY HARNESS
24	SB	TO BODY HARNESS
25	G	TO BODY HARNESS
26	B	TO BODY HARNESS
27	L	TO BODY HARNESS
100	SB	TO BODY HARNESS

## EXTERIOR LIGHTING SYSTEM

Connector No.	E105
Connector Name	WIRE TO WIRE
Connector Type	TH80FW-CS16-TM4
Connector Color	White

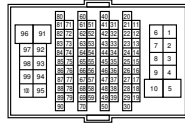

Terminal No.	Color Of Wire	Signal Name [Specification]
2	W	TO MAIN HARNESS
3	GR	TO MAIN HARNESS [Color of wire varies depending on production]
3	R	TO MAIN HARNESS [Color of wire varies depending on production]
4	P	TO MAIN HARNESS
5	V	TO MAIN HARNESS
8	L	TO MAIN HARNESS
9	LG	TO MAIN HARNESS
10	W	TO MAIN HARNESS
20	W	TO MAIN HARNESS
21	B	TO MAIN HARNESS
22	SHIELD	TO MAIN HARNESS
31	Y	TO MAIN HARNESS
33	P	TO MAIN HARNESS
34	Y	TO MAIN HARNESS
35	BG	TO MAIN HARNESS
36	LG	TO MAIN HARNESS
37	V	TO MAIN HARNESS
40	L	TO MAIN HARNESS
41	P	TO MAIN HARNESS
42	L	TO MAIN HARNESS
43	B	TO MAIN HARNESS
44	G	TO MAIN HARNESS
45	BG	TO MAIN HARNESS
46	W	TO MAIN HARNESS
51	P	TO MAIN HARNESS
52	L	TO MAIN HARNESS
53	W	TO MAIN HARNESS
54	Y	TO MAIN HARNESS
55	BR	TO MAIN HARNESS
56	P	TO MAIN HARNESS
57	B	TO MAIN HARNESS
58	BR	TO MAIN HARNESS
59	Y	TO MAIN HARNESS
60	G	TO MAIN HARNESS
63	BR	TO MAIN HARNESS

64	GR	TO MAIN HARNESS
65	LG	TO MAIN HARNESS
66	BG	TO MAIN HARNESS
67	R	TO MAIN HARNESS
68	V	TO MAIN HARNESS
69	P	TO MAIN HARNESS
70	L	TO MAIN HARNESS
71	V	TO MAIN HARNESS
72	L	TO MAIN HARNESS
73	R	TO MAIN HARNESS
74	G	TO MAIN HARNESS
76	L	TO MAIN HARNESS
77	V	TO MAIN HARNESS
78	LG	TO MAIN HARNESS
79	SHIELD	TO MAIN HARNESS
80	GR	TO MAIN HARNESS
81	BG	TO MAIN HARNESS
82	W	TO MAIN HARNESS
83	SB	TO MAIN HARNESS
84	L	TO MAIN HARNESS
85	P	TO MAIN HARNESS
86	Y	TO MAIN HARNESS
88	BG	TO MAIN HARNESS
89	V	TO MAIN HARNESS
90	BR	TO MAIN HARNESS [Color of wire varies depending on production]
90	LG	TO MAIN HARNESS [Color of wire varies depending on production]
91	R	TO MAIN HARNESS
93	W	TO MAIN HARNESS
95	BR	TO MAIN HARNESS
96	GR	TO MAIN HARNESS
97	BG	TO MAIN HARNESS [Color of wire varies depending on production]
97	R	TO MAIN HARNESS [Color of wire varies depending on production]
98	V	TO MAIN HARNESS
99	Y	TO MAIN HARNESS
100	LG	TO MAIN HARNESS

Connector No.	E112
Connector Name	BRAKE PEDAL POSITION SWITCH
Connector Type	M02FBR-LC
Connector Color	Brown



Terminal No.	Color Of Wire	Signal Name [Specification]
1	P	BRAKE PEDAL POSITION SWITCH
2	GR	BRAKE PEDAL POSITION SWITCH

Connector No.	E115
Connector Name	STOP LAMP SWITCH
Connector Type	M04FW-LC
Connector Color	White



Terminal No.	Color Of Wire	Signal Name [Specification]
1	V	STOP LAMP SWITCH POWER SUPPLY
2	LG	-
3	L	STOP LAMP SWITCH POWER SUPPLY
4	W	-

Connector No.	E122
Connector Name	HEADLAMP AIMING MOTOR RH
Connector Type	HS03FGY
Connector Color	Gray



Terminal No.	Color Of Wire	Signal Name [Specification]
1	-	-
2	-	-
3	-	-

Connector No.	E123
Connector Name	HEADLAMP AIMING MOTOR LH
Connector Type	HS03FGY
Connector Color	Gray



Terminal No.	Color Of Wire	Signal Name [Specification]
1	-	-
2	-	-
3	-	-

## EXTERIOR LIGHTING SYSTEM

Connector No.	E124
Connector Name	BRAKE PEDAL POSITION SWITCH
Connector Type	M02FBR-LC
Connector Color	Brown



Terminal No.	Color Of Wire	Signal Name [Specification]
1	P	BRAKE PEDAL POSITION SWITCH POWER SUPPLY
2	GR	BRAKE PEDAL POSITION SWITCH

Connector No.	E143
Connector Name	HEADLAMP AIMING MOTOR LH
Connector Type	HS03FGY
Connector Color	Gray



Terminal No.	Color Of Wire	Signal Name [Specification]
1	-	-
2	-	-
3	-	-

Connector No.	E144
Connector Name	HEADLAMP AIMING MOTOR RH
Connector Type	HS03FGY
Connector Color	Gray



Terminal No.	Color Of Wire	Signal Name [Specification]
1	-	-
2	-	-
3	-	-

Connector No.	E146
Connector Name	WIRE TO WIRE
Connector Type	TH16FW-NH
Connector Color	White

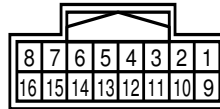

Terminal No.	Color Of Wire	Signal Name [Specification]
1	V	TO ENGINE ROOM HARNESS
2	L	TO ENGINE ROOM HARNESS
3	SB	TO ENGINE ROOM HARNESS
4	P	TO ENGINE ROOM HARNESS
5	G	TO ENGINE ROOM HARNESS
8	GR	TO ENGINE ROOM HARNESS
9	SHIELD	TO ENGINE ROOM HARNESS
10	LG	TO ENGINE ROOM HARNESS
11	V	TO ENGINE ROOM HARNESS
12	W	TO ENGINE ROOM HARNESS
13	LG	TO ENGINE ROOM HARNESS
15	V	TO ENGINE ROOM HARNESS
16	GR	TO ENGINE ROOM HARNESS

Connector No.	E148
Connector Name	IPDM E/R (INTELLIGENT POWER DISTRIBUTION MODULE ENGINE ROOM)
Connector Type	NS08FBR-CS
Connector Color	Brown

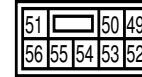

Terminal No.	Color Of Wire	Signal Name [Specification]
49	R	-
50	L	-
51	V	-
52	W	-
53	GR	-
54	LG	-
55	SB	-
56	BG	-

Connector No.	E149
Connector Name	IPDM E/R (INTELLIGENT POWER DISTRIBUTION MODULE ENGINE ROOM)
Connector Type	NS08FW-CS
Connector Color	White

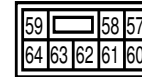

Terminal No.	Color Of Wire	Signal Name [Specification]
57	W	-
58	R	-
59	G	-
60	Y	-
61	GR	-
62	SB	-
63	B	-
64	V	-

Connector No.	E150
Connector Name	WIRE TO WIRE
Connector Type	M02FW-GY-LC
Connector Color	White



Terminal No.	Color Of Wire	Signal Name [Specification]
1	B	TO ENGINE ROOM HARNESS
2	B	TO ENGINE ROOM HARNESS

Connector No.	E151
Connector Name	FRONT COMBINATION LAMP RH
Connector Type	RS06FGY-PR
Connector Color	Gray



Terminal No.	Color Of Wire	Signal Name [Specification]
1	R	-
2	GR	-
3	GR	-
5	B	-
6	LG	-

## EXTERIOR LIGHTING SYSTEM

Connector No.	E152
Connector Name	FRONT COMBINATION LAMP RH
Connector Type	RS06FB-PR
Connector Color	Black



Terminal No.	Color Of Wire	Signal Name [Specification]
7	SB	-
8	B	-
10	SB	-
11	B	-
12	V	-

Connector No.	E153
Connector Name	FRONT COMBINATION LAMP LH
Connector Type	RS06FGY-PR
Connector Color	Gray



Terminal No.	Color Of Wire	Signal Name [Specification]
1	R	-
2	GR	-
3	BG	-
5	B	-
6	G	-

Connector No.	E154
Connector Name	FRONT COMBINATION LAMP LH
Connector Type	RS06FB-PR
Connector Color	Black



Terminal No.	Color Of Wire	Signal Name [Specification]
7	L	-
8	B	-
10	L	-
11	B	-
12	V	-

Connector No.	E155
Connector Name	FRONT COMBINATION LAMP RH
Connector Type	RS08FB-PR
Connector Color	Black

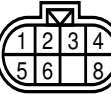

Terminal No.	Color Of Wire	Signal Name [Specification]
1	B	-
2	LG	-
3	SB	-
4	Y	-
5	R	-
6	GR	-
8	B	-

Connector No.	E156
Connector Name	FRONT COMBINATION LAMP LH
Connector Type	RS08FB-PR
Connector Color	Black

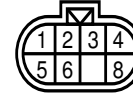

Terminal No.	Color Of Wire	Signal Name [Specification]
1	B	-
2	G	-
3	L	-
4	GR	-
5	R	-
6	BG	-
8	B	-

Connector No.	E158
Connector Name	FRONT FOG LAMP RH
Connector Type	FHZ02FB
Connector Color	Black



Terminal No.	Color Of Wire	Signal Name [Specification]
1	W	-
2	GR	-

Connector No.	E159
Connector Name	FRONT FOG LAMP LH
Connector Type	FHZ02FB
Connector Color	Black



Terminal No.	Color Of Wire	Signal Name [Specification]
1	V	-
2	GR	-

Connector No.	E162
Connector Name	FRONT COMBINATION LAMP LH
Connector Type	RS03FB
Connector Color	Black



Terminal No.	Color Of Wire	Signal Name [Specification]
9	L	-
10	B	-
11	V	-

## EXTERIOR LIGHTING SYSTEM

Connector No.	E163
Connector Name	FRONT COMBINATION LAMP RH
Connector Type	RS03FB
Connector Color	Black



Terminal No.	Color Of Wire	Signal Name [Specification]
9	SB	-
10	B	-
11	V	-

Connector No.	E175
Connector Name	JOINT CONNECTOR-E01
Connector Type	NH24FG-J
Connector Color	Green

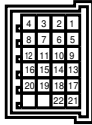

Terminal No.	Color Of Wire	Signal Name [Specification]
1	B	- [Color of wire varies depending on production]
1	V	- [Color of wire varies depending on production]
1	W	- [Color of wire varies depending on production]
2	B	-
3	P	-
4	L	-
5	B	- [Color of wire varies depending on production]
5	V	- [Color of wire varies depending on production]
5	W	- [Color of wire varies depending on production]
6	SHIELD	- [2WD models]
6	V	- [2WD & 4WD models]
7	P	-
8	L	-
9	W	-
10	LG	- [2WD & 4WD models]

10	SHIELD	- [2WD models]
11	P	-
12	L	-
13	B	-
14	LG	- [2WD & 4WD models]
14	SHIELD	- [2WD models]
15	P	-
16	L	-
17	Y	-
18	BR	- [Color of wire varies depending on production]
18	L	- [Color of wire varies depending on production]
19	P	-
20	L	-
21	Y	-
22	BR	- [Color of wire varies depending on production]
22	L	- [Color of wire varies depending on production]

Connector No.	E197
Connector Name	ECM
Connector Type	RH24FB-RZ8-L-LH
Connector Color	Black

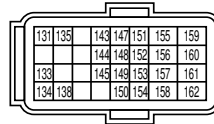

Terminal No.	Color Of Wire	Signal Name [Specification]
131	BR	FTPRES
133	P	VEHCAN-L
134	L	VEHCAN-H
135	R	AVCC3-FTPRES(NAM)
138	BG	TF
143	LG	IGNSW
144	G	ASCDSW
145	BR	GND-ASCDSW
147	P	PrivateCAN-L
148	L	PrivateCAN-H
149	V	BRAKE
150	GR	BNCDSW
151	GR	CDCV
152	SB	AVCC2-APS2
153	Y	APS2
154	LG	GND-APS2
155	BR	VBR

156	V	AVCC1-APS1
157	B	GND
158	V	GND-FTPRES/TF
159	B	GND
160	GR	APS1
161	R	GND-APS1
162	B	GND

Connector No.	F22
Connector Name	TRANSMISSION RANGE SWITCH
Connector Type	YDX06FB-HS4
Connector Color	Black

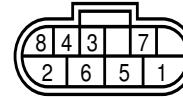

Terminal No.	Color Of Wire	Signal Name [Specification]
1	BG	TRANSMISSION RANGE SWITCH POWER SUPPLY
2	GR	TRANSMISSION RANGE SWITCH POWER SUPPLY
3	W	-
4	V	P RANGE SWITCH
5	G	R RANGE SWITCH
6	BR	N RANGE SWITCH
7	Y	D RANGE SWITCH
8	GR	L RANGE SWITCH

Connector No.	F72
Connector Name	IPDM E/R (INTELLIGENT POWER DISTRIBUTION MODULE ENGINE ROOM)
Connector Type	NS16FW-CS
Connector Color	White

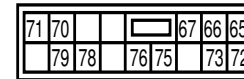

Terminal No.	Color Of Wire	Signal Name [Specification]
65	P	-
66	L	- [4WD models]
66	R	- [2WD models]
67	V	-
70	BG	-
71	SB	-
72	GR	-
73	BR	- [4WD models]
73	Y	- [2WD models]
75	BR	-
76	P	-
78	BG	- [Color of wire varies depending on production]
78	V	- [Color of wire varies depending on production]
79	G	-

Connector No.	F121
Connector Name	WIRE TO WIRE
Connector Type	NS16FBR-CS
Connector Color	Brown

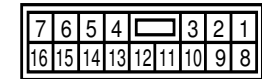

Terminal No.	Color Of Wire	Signal Name [Specification]
1	B	TO ENGINE ROOM HARNESS [Color of wire varies depending on production]
1	BR	TO ENGINE ROOM HARNESS [Color of wire varies depending on production]
2	BR	TO ENGINE ROOM HARNESS [Color of wire varies depending on production]
2	GR	TO ENGINE ROOM HARNESS [Color of wire varies depending on production]
3	BG	TO ENGINE ROOM HARNESS [4WD models]
3	R	TO ENGINE ROOM HARNESS [2WD models]
4	BG	TO ENGINE ROOM HARNESS
5	L	TO ENGINE ROOM HARNESS [2WD models]
5	R	TO ENGINE ROOM HARNESS [4WD models]
6	BG	TO ENGINE ROOM HARNESS [Color of wire varies depending on production]
6	BR	TO ENGINE ROOM HARNESS [Color of wire varies depending on production]
7	G	TO ENGINE ROOM HARNESS
8	V	TO ENGINE ROOM HARNESS [2WD models]
8	W	TO ENGINE ROOM HARNESS [4WD models]
9	B	TO ENGINE ROOM HARNESS [Color of wire varies depending on production]
9	BR	TO ENGINE ROOM HARNESS [Color of wire varies depending on production]
9	V	TO ENGINE ROOM HARNESS [Color of wire varies depending on production]

## EXTERIOR LIGHTING SYSTEM

10	BR	TO ENGINE ROOM HARNESS
11	G	TO ENGINE ROOM HARNESS [With MR engine]
11	P	TO ENGINE ROOM HARNESS [Without MR engine]
12	GR	TO ENGINE ROOM HARNESS
13	BR	TO ENGINE ROOM HARNESS [Color of wire varies depending on production]
13	Y	TO ENGINE ROOM HARNESS [Color of wire varies depending on production]
14	R	TO ENGINE ROOM HARNESS
15	L	TO ENGINE ROOM HARNESS
16	LG	TO ENGINE ROOM HARNESS [4WD models]
16	SB	TO ENGINE ROOM HARNESS [2WD models]

Connector No.	M1
Connector Name	FUSE BLOCK (J/B)
Connector Type	CS06FW-M2
Connector Color	White

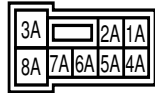

Terminal No.	Color Of Wire	Signal Name [Specification]
1A	L	-
2A	LG	-
3A	Y	-
4A	LG	-
5A	R	-
6A	BG	-
7A	LA/BR	-
8A	SB	-

Connector No.	M2
Connector Name	FUSE BLOCK (J/B)
Connector Type	NS16FBR-CS
Connector Color	Brown

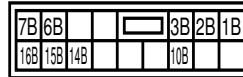

Terminal No.	Color Of Wire	Signal Name [Specification]
10B	GR	-
14B	W	-
15B	W	-
16B	GR	-
1B	G	- [Color of wire varies depending on production]
1B	V	- [Color of wire varies depending on production]
2B	G	- [Color of wire varies depending on production]
2B	R	- [Color of wire varies depending on production]
3B	V	-
6B	LA/L	-
7B	LA/V	-

Connector No.	M3
Connector Name	FUSE BLOCK (J/B)
Connector Type	NS16FW-CS
Connector Color	White

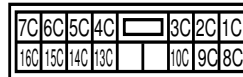

Terminal No.	Color Of Wire	Signal Name [Specification]
10C	LG	-
13C	LA/G	-
14C	LG	-
15C	L	-
16C	LA/W	-
1C	R	-
2C	G	-

3C	LA/Y	-
4C	LG	-
5C	GR	-
6C	LA/R	-
7C	Y	-
8C	BR	- [Color of wire varies depending on production]
8C	LA/BR	- [Color of wire varies depending on production]
9C	L	-

Connector No.	M6
Connector Name	HEADLAMP AIMING SWITCH
Connector Type	TH04FW-NH
Connector Color	White



Terminal No.	Color Of Wire	Signal Name [Specification]
1	V	HEADLAMP AIMING SWITCH POWER SUPPLY
2	GR	HEADLAMP AIMING SWITCH GROUND
3	G	-
4	LG	- [Color of wire varies depending on production]
4	R	- [Color of wire varies depending on production]

Connector No.	M18
Connector Name	WIRE TO WIRE
Connector Type	TH24MW-NH
Connector Color	White

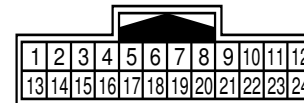

Terminal No.	Color Of Wire	Signal Name [Specification]
1	B	TO DOOR HARNESS
2	B	TO DOOR HARNESS
3	Y	TO DOOR HARNESS

4	V	TO DOOR HARNESS
5	BR	TO DOOR HARNESS
6	LG	TO DOOR HARNESS
7	L	TO DOOR HARNESS
8	Y	TO DOOR HARNESS
9	G	TO DOOR HARNESS
10	SHIELD	TO DOOR HARNESS
11	R	TO DOOR HARNESS
13	GR	TO DOOR HARNESS
14	LA/SB	TO DOOR HARNESS
15	LA/GR	TO DOOR HARNESS
16	LA/V	TO DOOR HARNESS
17	LA/L	TO DOOR HARNESS
18	LA/BG	TO DOOR HARNESS
19	LA/R	TO DOOR HARNESS
22	LA/G	TO DOOR HARNESS
23	BG	TO DOOR HARNESS
24	SB	TO DOOR HARNESS

Connector No.	M19
Connector Name	WIRE TO WIRE
Connector Type	NS16MW-CS
Connector Color	White

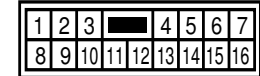

Terminal No.	Color Of Wire	Signal Name [Specification]
1	V	TO DOOR HARNESS
2	LA/R	TO DOOR HARNESS
3	G	TO DOOR HARNESS
4	B	TO DOOR HARNESS
6	L	TO DOOR HARNESS [With 8-speakers]
6	LA/Y	TO DOOR HARNESS [With 4-speakers]
6	Y	TO DOOR HARNESS [With 6-speakers]
7	BR	TO DOOR HARNESS [With 8-speakers]
7	LA/R	TO DOOR HARNESS [With 4-speakers]
7	R	TO DOOR HARNESS [With 6-speakers]
8	L	TO DOOR HARNESS
9	BR	TO DOOR HARNESS
10	GR	TO DOOR HARNESS
11	Y	TO DOOR HARNESS
12	BG	TO DOOR HARNESS

## EXTERIOR LIGHTING SYSTEM

13	LA/G	TO DOOR HARNESS
14	LA/R	TO DOOR HARNESS
15	P	TO DOOR HARNESS
16	B	TO DOOR HARNESS

Connector No.	M31
Connector Name	COMBINATION SWITCH
Connector Type	TH16FW-NH
Connector Color	White

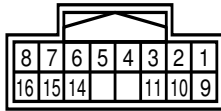

Terminal No.	Color Of Wire	Signal Name [Specification]
1	LG	INPUT_5
2	SB	OUTPUT_1
3	GR	INPUT_4
4	BG	OUTPUT_4
5	G	INPUT_3
6	W	INPUT_2
7	Y	OUTPUT_5
8	V	INPUT_1
9	G	RR_WASH_MOTOR
10	BR	OUTPUT_2
11	Y	FR_WASH_MOTOR
14	LG	IGN
15	P	OUTPUT_3
16	GR	GROUND

Connector No.	M45
Connector Name	HAZARD SWITCH
Connector Type	TH04FW-NH
Connector Color	White

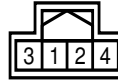

Terminal No.	Color Of Wire	Signal Name [Specification]
1	GR	HAZARD SWITCH GROUND
2	Y	HAZARD SW
3	R	ILLUMINATION CONTROL SIGNAL
4	GR	HAZARD SWITCH GROUND

Connector No.	M77
Connector Name	WIRE TO WIRE
Connector Type	TH80MW-CS16-TM4
Connector Color	White

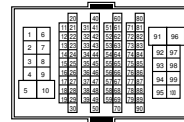

Terminal No.	Color Of Wire	Signal Name [Specification]
2	LA/R	TO ENGINE ROOM HARNESS
3	R	TO ENGINE ROOM HARNESS
4	BR	TO ENGINE ROOM HARNESS
5	V	TO ENGINE ROOM HARNESS
8	G	TO ENGINE ROOM HARNESS
9	Y	TO ENGINE ROOM HARNESS
10	R	TO ENGINE ROOM HARNESS
20	W	TO ENGINE ROOM HARNESS
21	B	TO ENGINE ROOM HARNESS
22	SHIELD	TO ENGINE ROOM HARNESS
31	V	TO ENGINE ROOM HARNESS
33	P	TO ENGINE ROOM HARNESS
34	Y	TO ENGINE ROOM HARNESS
35	BG	TO ENGINE ROOM HARNESS

36	LG	TO ENGINE ROOM HARNESS
37	V	TO ENGINE ROOM HARNESS
40	L	TO ENGINE ROOM HARNESS
41	P	TO ENGINE ROOM HARNESS
42	L	TO ENGINE ROOM HARNESS
43	B	TO ENGINE ROOM HARNESS
44	G	TO ENGINE ROOM HARNESS
45	LA/V	TO ENGINE ROOM HARNESS
46	LA/Y	TO ENGINE ROOM HARNESS
51	GR	TO ENGINE ROOM HARNESS
52	SB	TO ENGINE ROOM HARNESS
53	R	TO ENGINE ROOM HARNESS
54	LA/L	TO ENGINE ROOM HARNESS
55	BR	TO ENGINE ROOM HARNESS
56	SB	TO ENGINE ROOM HARNESS
57	B	TO ENGINE ROOM HARNESS
58	L	TO ENGINE ROOM HARNESS
59	V	TO ENGINE ROOM HARNESS
60	LA/R	TO ENGINE ROOM HARNESS
63	LA/BR	TO ENGINE ROOM HARNESS
64	Y	TO ENGINE ROOM HARNESS
65	GR	TO ENGINE ROOM HARNESS
66	BG	TO ENGINE ROOM HARNESS
67	G	TO ENGINE ROOM HARNESS
68	B	TO ENGINE ROOM HARNESS
69	P	TO ENGINE ROOM HARNESS
70	L	TO ENGINE ROOM HARNESS
71	V	TO ENGINE ROOM HARNESS
72	L	TO ENGINE ROOM HARNESS
73	Y	TO ENGINE ROOM HARNESS
74	G	TO ENGINE ROOM HARNESS
76	L	TO ENGINE ROOM HARNESS
77	V	TO ENGINE ROOM HARNESS
78	LG	TO ENGINE ROOM HARNESS
79	SHIELD	TO ENGINE ROOM HARNESS
80	L	TO ENGINE ROOM HARNESS [With stop/start system]
80	LA/L	TO ENGINE ROOM HARNESS [Without stop/start system]
81	LA/V	TO ENGINE ROOM HARNESS
82	LA/Y	TO ENGINE ROOM HARNESS
83	LG	TO ENGINE ROOM HARNESS
84	SB	TO ENGINE ROOM HARNESS
85	P	TO ENGINE ROOM HARNESS
86	Y	TO ENGINE ROOM HARNESS
88	BG	TO ENGINE ROOM HARNESS
89	V	TO ENGINE ROOM HARNESS
90	BR	TO ENGINE ROOM HARNESS [Color of wire varies depending on production]
90	LG	TO ENGINE ROOM HARNESS [Color of wire varies depending on production]
91	L	TO ENGINE ROOM HARNESS [Color of wire varies depending on production]
91	R	TO ENGINE ROOM HARNESS [Color of wire varies depending on production]
93	W	TO ENGINE ROOM HARNESS

95	BR	TO ENGINE ROOM HARNESS
96	GR	TO ENGINE ROOM HARNESS [Color of wire varies depending on production]
96	LG	TO ENGINE ROOM HARNESS [Color of wire varies depending on production]
97	BR	TO ENGINE ROOM HARNESS
98	V	TO ENGINE ROOM HARNESS
99	R	TO ENGINE ROOM HARNESS
100	LG	TO ENGINE ROOM HARNESS

Connector No.	M81
Connector Name	WIRE TO WIRE
Connector Type	TH24MW-NH
Connector Color	White

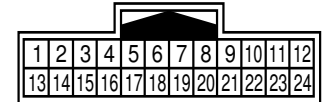

Terminal No.	Color Of Wire	Signal Name [Specification]
1	B	TO DOOR HARNESS
3	B	TO DOOR HARNESS [Color of wire varies depending on production]
3	GR	TO DOOR HARNESS [Color of wire varies depending on production]
4	W	TO DOOR HARNESS
5	P	TO DOOR HARNESS
6	SB	TO DOOR HARNESS
7	B	TO DOOR HARNESS
8	L	TO DOOR HARNESS
9	Y	TO DOOR HARNESS
10	SHIELD	TO DOOR HARNESS
11	G	TO DOOR HARNESS
13	LA/SB	TO DOOR HARNESS
14	LA/GR	TO DOOR HARNESS
15	LA/V	TO DOOR HARNESS
16	LA/L	TO DOOR HARNESS
17	LA/BG	TO DOOR HARNESS
18	GR	TO DOOR HARNESS
21	LA/Y	TO DOOR HARNESS

## EXTERIOR LIGHTING SYSTEM

Connector No.	M82
Connector Name	WIRE TO WIRE
Connector Type	NS16MW-CS
Connector Color	White



1	2	3	4	5	6	7		
8	9	10	11	12	13	14	15	16

Terminal No.	Color Of Wire	Signal Name [Specification]
1	B	TO DOOR HARNESS
2	B	TO DOOR HARNESS [Color of wire varies depending on production]
2	GR	TO DOOR HARNESS [Color of wire varies depending on production]
8	SB	TO DOOR HARNESS
9	BR	TO DOOR HARNESS
10	GR	TO DOOR HARNESS
11	L	TO DOOR HARNESS
12	Y	TO DOOR HARNESS
13	GR	TO DOOR HARNESS [With 6-speakers]
13	LA/GR	TO DOOR HARNESS [With 4-speakers]
13	LA/R	TO DOOR HARNESS [With 8-speakers]
14	LA/SB	TO DOOR HARNESS [With 8-speakers]
14	LA/W	TO DOOR HARNESS [With 4-speakers]
14	W	TO DOOR HARNESS [With 6-speakers]

Connector No.	M85
Connector Name	BCM (BODY CONTROL MODULE)
Connector Type	NS16FBR-CS
Connector Color	Brown



143	141	139	138	137		
152	151	148	147	146	145	144

Terminal No.	Color Of Wire	Signal Name [Specification]
137	W	BAT POWER SUPPLY (FUSE)
138	SB	INT ROOM LAMP CONT
139	L	PASSENGER DOOR UNLOCK OUTPUT
141	V	FRONT DOOR LOCK OUTPUT

143	LA/V	POWER SUPPLY (FR DOOR LK ACT)
144	BG	POWER SUPPLY (TURN SIGNAL)
145	GR	POWER SUPPLY (STOP LAMP)
146	B	GROUND
147	B	GROUND
148	G	DRIVER DOOR UNLOCK OUTPUT
151	R	POWER SUPPLY (REAR DOOR LK ACT)
152	LG	POWER SUPPLY (REAR WIPER)

Connector No.	M86
Connector Name	BCM (BODY CONTROL MODULE)
Connector Type	TH40FB-NH
Connector Color	Black



100	99	95	94	90	88	87	86	85	84	82	
120	119	118	115	114	112	110	108	107	105	104	101

Terminal No.	Color Of Wire	Signal Name [Specification]
82	W	PASS DOOR REQ SW
84	BR	COMBI SW OUTPUT 2
85	SB	COMBI SW OUTPUT 1
86	P	COMBI SW OUTPUT 3
87	BG	COMBI SW OUTPUT 4
88	W	PUSH-BTN IGN SW ILL CONT
90	Y	S/L CONDITION
94	G	DETENTION SW
95	V	EXTENDED STORAGE FUSE SW
99	R	STOP/START OFF SW
100	V	DRIVER DOOR ANT +
101	Y	PUSH SW (WITH S/L)
104	LA/R	DR DOOR UNLK SENS
105	Y	DR DOOR REQ SW
106	W	ACC OUTPUT
110	BG	DIMMER SIGNAL
112	SB	STOP/START OFF SW INDICATOR
114	Y	NATS ANTENNA AMP.
115	W	NATS ANTENNA AMP.
118	SB	PASSENGER DOOR ANT -
119	P	PASSENGER DOOR ANT +
120	BR	RRIVER DOOR ANT +

Connector No.	M87
Connector Name	BCM (BODY CONTROL MODULE)
Connector Type	TH40FGY-NH
Connector Color	Gray



59	57	52	51	50	49	48	46	45	44	43	42	41	
80	79	78	77	76	75	74	73	70	68	67	65	64	63

Terminal No.	Color Of Wire	Signal Name [Specification]
41	V	STEERING LOCK UNIT OPERATION POWER SUPPLY
42	LA/G	TURN SIG LH (SIDE)
43	LA/Y	TURN SIG RH (SIDE)
44	P	INTERIOR ROOM LAMP RELAY CONT
45	R	CAN-L
46	L	CAN-H
48	L	CAN-H
49	R	CAN-L
50	BG	DOOR LOCK SW
51	Y	HAZARD SW
52	W	SENSOR POWER SUPPLY
57	L	CVT SHIFT SELECT (DETENT SW) PWR
59	LG	OPTICAL SENSOR
63	G	POWER WINDOW RELAY CON
64	LA/R	REAR WINDOW DEFOGGER RELAY CONT
65	LA/BR	ACC RELAY CONT
67	LA/Y	IGN RELAY (F/B) CONT OUTPUT
68	LA/W	BLOWER RELAY CONT
70	V	SENSOR GROUND
73	LG	COMBI SW INPUT 5
74	Y	COMBI SW OUTPUT 5
75	BG	SECURITY IND LAMP CONT
76	G	COMBI SW INPUT 3
77	GR	COMBI SW INPUT 4
78	V	COMBI SW INPUT 1
79	W	COMBI SW INPUT 2
80	SB	DOOR UNLOCK SW

Connector No.	M136
Connector Name	OPTICAL SENSOR
Connector Type	TK03FW
Connector Color	White



1	2	3
---	---	---

Terminal No.	Color Of Wire	Signal Name [Specification]
1	W	SENSOR POWER SUPPLY
2	LG	OPTICAL SENSOR
3	V	SENSOR GROUND

Connector No.	M145
Connector Name	JOINT CONNECTOR-M14
Connector Type	SAC08JW
Connector Color	-



8	7	6	5	4	3	2	1
---	---	---	---	---	---	---	---

Terminal No.	Color Of Wire	Signal Name [Specification]
1	SB	-
2	SB	-
3	Y	-
4	SB	-
5	SB	-
6	SB	-
7	SB	-
8	SB	-

## EXTERIOR LIGHTING SYSTEM

Connector No.	M148
Connector Name	JOINT CONNECTOR-M17
Connector Type	SAC08JW
Connector Color	-

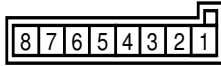

Connector No.	M154
Connector Name	JOINT CONNECTOR-M20
Connector Type	SAC08JW
Connector Color	-

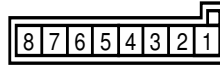

Terminal No.	Color Of Wire	Signal Name [Specification]
1	B	-
2	B	-
3	B	-
4	B	-
5	B	-
6	B	-
7	B	-
8	B	-

Terminal No.	Color Of Wire	Signal Name [Specification]
1	B	-
2	B	-
3	B	-
4	B	-
5	B	-
6	B	-
7	B	-
8	B	-

Connector No.	M150
Connector Name	JOINT CONNECTOR-M19
Connector Type	SAC08JW
Connector Color	-

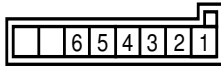

Connector No.	M170
Connector Name	JOINT CONNECTOR-M24
Connector Type	SAC08JW
Connector Color	-

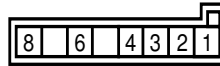

Terminal No.	Color Of Wire	Signal Name [Specification]
1	GR	-
2	GR	-
3	GR	-
4	GR	-
5	GR	-
6	GR	-

Terminal No.	Color Of Wire	Signal Name [Specification]
1	GR	-
2	GR	-
3	GR	-
4	GR	-
6	GR	-
8	GR	-